

# ***SAFETY VALVES***

## ***10000 SERIES***

### ***USE AND MAINTENANCE MANUAL***

## SAFETY VALVE FOR GASES, VAPOURS AND LIQUIDS

### Characteristics

- Homologation ISPESEL n° VS/403/96;
- overpressure 10%;
- blowdown 7%;
- spring range  $\pm 5\%$  of set pressure;
- gases and vapours discharge coefficient  $K= 0,96$  ISPESEL homologated;
- liquid discharge  $k= 0,6$ .

### Accessories

- Test gag;
- soft seat;
- balancing bellows;
- lifting lever;
- heating jacket.

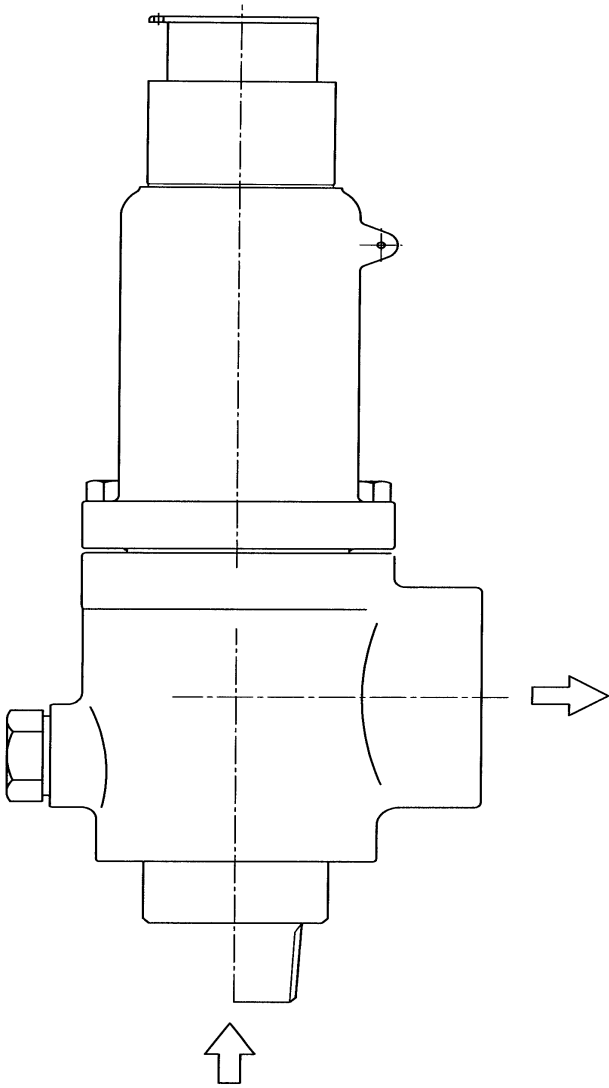

### CHARACTERISTICS AND PRESSURE LIMITS

Type	Orifice				Lift mm	Max. set pressure bar	Max. back pressure	
	mm	in	cm <sup>2</sup>	Sq. in			without bellows bar	with bellows bar
D	10	0.39	0.785	0.12	2.1	413	28	10
E	13.5	0.53	1.43	0.22	3.2	330	28	10
F	17.5	0.69	2.4	0.37	4.2	300	28	10
G	21.5	0.85	3.63	0.56	5.5	280	28	10
H	27	1.06	5.72	0.88	7	30	10	10

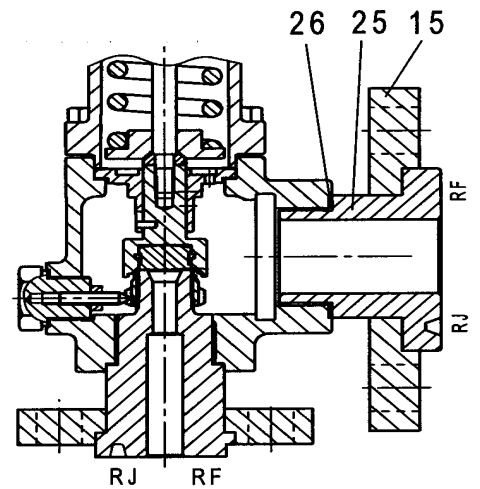
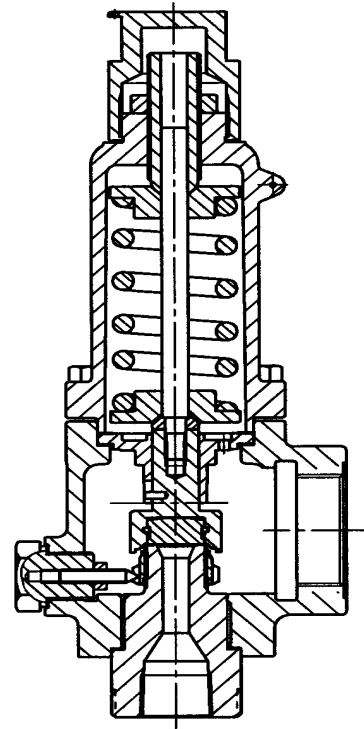
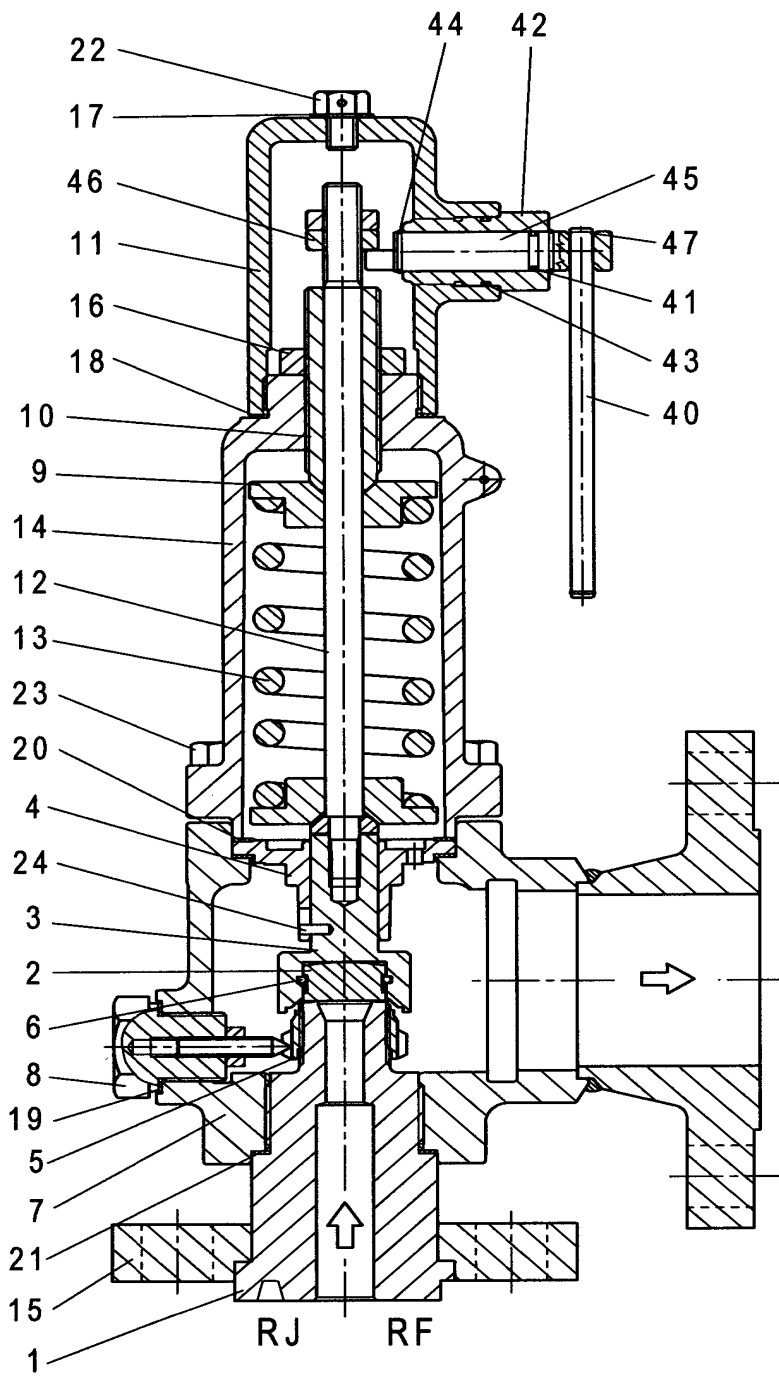

---

## 10000 SERIES SAFETY VALVES

Safety valves **10000 Series**, designed and manufactured by **Technical s.r.l.** in accordance with international standards, are full nozzle and total lift type. They possess a high discharge coefficient ( $k=0.96$ ), certified by **I.S.P.E.S.L.** on the basis of experimental tests performed by authorized laboratories; are suitable for gaseous and liquid fluids.

The body and the bonnet are made from casting. The bonnet contains the spiral spring or bellville spring depending on the use and type of fluid.

The seat is plane and "metal on metal" type; it is possible to add valves with a soft sealing ring (FPM rubber). Upon request, the valve is also available with accessories such as the packed lifting lever, test gag, and balancing-isolation bellows.

### 1. INSTALLING

Before installing the valve on the plant make sure that:

- the line fluid is indicated on the construction declaration or is compatible with what stated in it;
- the inlet piping the valve are impurities less, slag etc. and eventually remove them.
- the inlet and discharge piping are dimensioned in such a way that they generate the minimum possible loss of pressure.

In case the valve that is going to be installed is a **threaded type** use for tightening the key of the nozzle (1); if the valve is a **flanged type** tighten the bolts in a uniform way.

Once the valve has been installed on the plant make sure that:

- the discharge is not positioned in such a way to result dangerous for people or for instruments;
- the discharge is properly conveyed .

#### 1.1 SETTING UP

Before shipment all the safety valves are hydrostatically tested and set at the setting pressure required by the Client. Therefore regulation in loco should not be necessary.

The maximum setting error is less than 3% for pressure up to 21 bar, with a minimum of 0,2 bar; it is less than 0,7 bar up to 70 bar; it is less than 1% for pressure over 70 bar.

In case it should be necessary to modify the set pressure or the re-closure pressure of the valve (blowdown) , it should be necessary proceed as follows:

##### 1.1.1 setting regulation ( referring to drawing )

In order to carry out setting regulation of the valve it is necessary:

- remove the cap (11) and unloosen the lock nut (16);
- turn the adjusting screw (10) clockwise in case the set pressure should be increased;
- turn the adjusting screw (10) counter clockwise in case the pressure should be decreased.

The adjustment range of the spring setting is  $\pm 5\%$  of the set pressure indicated on the label of the valve.

Once the valve setting is regulated tighten the lock nut (16) and re-screw the bonnet cap (11).

##### 1.1.2 blowdown ring regulation (table 1)

In order to carry out the regulation of the blowdown ring execute the following operations:

- loosen the test gag (8);
- lift the blowdown ring (5) turn it counter-clockwise until touch the disc holder (3);
- withdraw the blowdown ring (5), turn it clockwise, as indicated in **table 1**;
- tighten the test gag (8) being assured that it does not block the blowdown ring (5) but that it stops the blowdown ring to turn only.

In case a more precise regulation of the ring (blowdown) is required, it is necessary carry it out with the valve installed on the plant and full flow, taking into consideration that:

- reducing the number of withdrawing notches it is favoured the opening and it is delayed the re-closure;
- increasing the number of withdrawing notches it is delayed the full opening and it is favoured the re-closure.

TABLE 1

<b>BLOWDOWN RING ADJUSTING</b>			
<b>SET PRESSURE</b>	<b>N° OF NOTCHES FROM CONTACT POSITION</b>		
<b>ate</b>	<b>D</b>	<b>ORIFICE E</b>	<b>F-G-H</b>
0.5 - 7	1 - 2	1 - 2	2 - 3
8 - 15	4 - 5	5 - 6	4 - 8
16 - 25	5 - 6	6 - 7	8 - 10
26 - 40	6 - 9	7 - 10	10 - 13
41 - 60	9 - 12	10 - 13	13 - 16
61 - 90	12 - 15	13 - 17	16 - 19
91 - 125	15 - 18	17 - 20	19 - 22
126 - 190	18 - 21	20 - 23	22 - 25
191 - 280	21 - 24	23 - 26	25 - 28
281 - 360	24 - 27	26 - 29	28 - 31

## 2. DISASSEMBLING

### 2.1 VALVE WITHOUT ACCESSORIES

In order to execute disassembling carry out progressively the following operations:

**CAUTION :** before disassembling the valve make sure that the plant on which it is mounted is not “under pressure” and that no pressure inside the valve itself has remained.

- remove the valve from the plant;
- remove the cap (11) and unloosen the lock nut (16)
- unloosen the adjusting screw (10);

**CAUTION :** before disassembling the bonnet of the valve body make sure that the spring (13) is totally released using the adjusting screw (10).

- remove the screws (23), the bonnet (14) and remove all the internal parts.

### 2.2 VALVE WITH LEVER

In order to execute the disassembling of the valve with lever carry out progressively the following operations:

**CAUTION :** before disassembling the valve make sure that the plant on which it is mounted is not “under pressure” and that no pressure inside the valve itself has remained.

- hold the lever (40) downwards and remove the lever guide (42) turning it counter clockwise;
- remove the rings (44) and (47) , the lever (40) and the camshaft (45);
- remove the cap (11);

Before removing the nuts (46) it is suggested to point out the distance between the bonnet and the lower lock nut in order to facilitate the next lever-group assembling.

- remove the nuts (46) and loosen the lock nut (16) ;
- loosen the adjusting screw (10);

**CAUTION :** before disassembling the bonnet of the valve body make sure that the spring (13) is totally released using the adjusting screw (10).

- remove the screws (23), the bonnet (14) and remove all the internal parts.

### 3. ASSEMBLING

#### 3.1 VALVE WITHOUT ACCESSORIES

For assembling carry out the same operations of point 2.1) but in reverse order, tightening first the nozzle (1) to the valve body (7). Before pushing the spring (13), make sure that the blowdown ring (5) is free and does not touch the disc holder (3).

#### 3.2 VALVE WITH LEVER

For assembling carry out the same operations of point 2.2) but in reverse order, tightening first of all the nozzle (1) to valve body (7). Before pushing the spring (13), make sure that the blowdown ring (5) is free and does not touch the disc holder (3).

Once re-assembled the valve and tightened the lock out (16) it is necessary to re-position the lever nuts (46) at the measure taken during the disassembling and tightening one against the other.

Screw the cap (11) and re-assembling in the following order

- camshaft (45) in the lever guide (42) and lever (40) in the camshaft ; rings (44) and (47) in their seats;
- hold the lever (40) downwards and assemble the lever guide (42) turning it clockwise;
- before to tighten it, make sure that camshaft (45) remains **0,2÷0,3 mm** from the nuts (46), after tighten the lever guide (42) .

After assembling make sure that the lever can turn for 1/8 of turn easily with no efforts and without interfere with the stem (12); if it would not be so proceed with a new regulation of nuts (46) or with a camshaft check.

### 4. MAINTENANCE

The safety valves requires an ordinary but careful maintenance ( **SEE MAINTENANCE PLANT** ) and in case it should be necessary , follow the operation stated in point 2) for disassembling and in point 3) for assembling.

In case of seat damaging it is necessary to carry out a new lapping: this operation has to be executed by skilled workers.

In case inconvenience should occur to the valve, verify if in the **DAMAGES TABLE** are contained some useful instructions for solving the problem.

In case the inconvenience is of different nature from what stated in the table, contact our Service Dept.

#### **WARNING**

- **The safety valves should not be subjected to bumps or such stresses that could compromise the working.**
- **High loads on the spring can damage the valve.**
- **The safety valves must be used only exclusively for the use stated in the construction declaration.**
- **The safety valve must be revised within two years from installation independently on the number of interventions executed by the valve.**

### ACCESSORIES

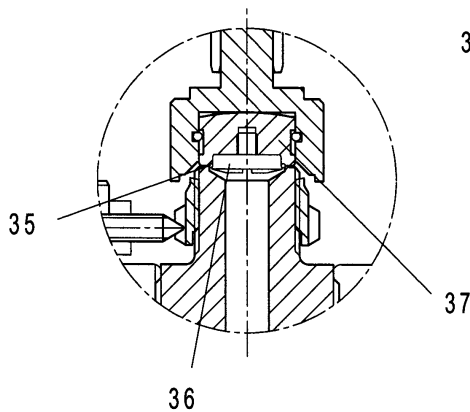

**SOFT SEAT**

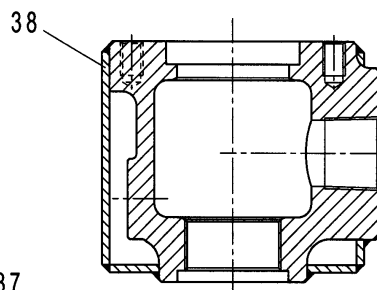

**JACKET**

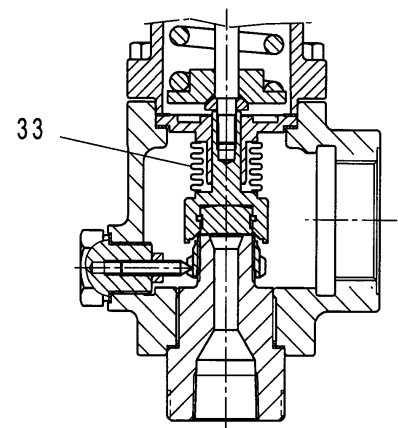

**BELLOWS**

## ORDINARY MAINTENANCE PLAN

Check of the seat and disc on the plant	Every valve opening or every 6-month working.
Check of the seal outwards in case of back pressure on the plant.	Every 30 days.
Check of the painting condition on the plant.	Every 6 months.
Ordinary maintenance of the valve assembled on the plant, including the seal check and surface check of the movable components.	Every 12-month working.
General maintenance of the valve removed from the plant including the disassembling, the seat and the disc check, the possible seat and disc lapping, gaskets substitution, painting restoration and inspection on the test bench.	Every opening with seats damaging or every 24-month working.

## DAMAGES TABLE

<b>INCONVENIENT</b>	<b>POSSIBLE DAMAGE</b>	<b>ACTION TO BE CARRIED OUT</b>
Fluid leakage in-line	Seat wear and tear	Nozzle substitution or revision
	Disc wear and tear	Disc substitution or revision
	Seat and disc damaging	Nozzle and disc revision
	Impurities presence between seat and disc	Nozzle and disc cleaning and revision
	Valve-use with fluid different from the one stated in the purchase order	Nozzle and disc revision
External back pressure fluid leakage.	Bellows breakage	Bellows substitution
	Valve gaskets damaging	Gaskets substitution
	Valve body-bonnet damaging	Valve revision or substitution
	Cap or blowdown screw loosen	Check and setting-up of the cap and of the blowdown screw.
Opening at pressure value different from setting valve	Back pressure changeable	Check of dimensioning and of the discharge piping working conditions and possible valve substitution with another balanced type.
	Spring release	Spring substitution and check compatibility of the material with the fluid.
	Setting screw withdraw	Resetting the valve and tighten very well the lock nut
Valve intervention with quick opening and re-closures repeated in the time	Strong loss load in the inlet piping	Check the inlet piping length
	Not correct setting-up of the blowdown ring	Withdraw the blowdown ring until obtain a proper working, basing the first regulation one table 1; for liquid fluids withdraw the blowdown ring completely.
	Pulsating flow rate to be discharged	Check plant regulation.
	Overdimensioned valve	Substitute the valve with one correctly dimensioned.

**MATERIAL TABLE SAFETY VALVE 10000 SERIES**

TEMPERATURE LIMITE °C		- 29° ÷ 426°		- 196° ÷ 426°			- 196° ÷ 100°
ITEM	PARTS	16 ①	18 ②	40 ③	60 ④	66 ⑤	93 ⑥
1	NOZZLE	AISI 316	AISI 316	AISI 304	AISI 316	AISI 316	BRONZE
2	DISC	17-4PH	AISI 316	AISI 304	17-4PH	17-4PH	C.ALUMINIUM
3	DISC HOLDER	17-4PH	17-4PH	17-4PH	17-4PH	17-4PH	BRONZE
4	GUIDE	AISI 304	AISI 304	AISI 304	AISI 304	AISI 304	BRONZE
5	BLOWDOWN RING	AISI 304	AISI 304	AISI 304	AISI 304	AISI 304	AISI 304
6	RING	AISI 316	AISI 316	AISI 316	AISI 316	AISI 316	AISI 316
7	BODY	A 216WCB	A 216WCB	A 351CF8	A 351CF8M	A 351CF8M	BRONZE
8	BLOWDOWN SCREW	AISI 303	AISI 303	AISI 303	AISI 303	AISI 303	AISI 303
9	SPRING GUIDE	C.STEEL/ ST.STEEL	C.STEEL/ ST.STEEL	ST.STEEL	ST.STEEL	ST.STEEL	ST.STEEL
10	ADJUSTING SCREW	AISI 431	AISI 431	AISI 431	AISI 431	AISI 431	BRASS
11	CAP	CARB.STEEL	CARB.STEEL	AISI 304	AISI 304	AISI 304	BRASS
12	STEM	AISI 304	AISI 304	AISI 304	AISI 304	AISI 304	AISI 304
13	SPRING	C.STEEL/ ST.STEEL	C.STEEL/ ST.STEEL	ST.STEEL	ST.STEEL	ST.STEEL	ST.STEEL
14	BONNET	A 216WCB	A 216WCB	A 351CF8	A 351CF8M	A 351CF8M	BRONZE
15	INLET FLANGE	CARB.STEEL	CARB.STEEL	AISI 304	AISI 316	AISI 316	AISI 316
16	LOCK NUT	AISI 303	AISI 303	AISI 303	AISI 303	AISI 303	AISI 303
17	GASKET	ALUMINIUM	ALUMINIUM	AISI 304	AISI 304	AISI 304	ALUMINIUM
18	GASKET	ARAM.FIBER	ARAM.FIBER	ARAM.FIBER	ARAM.FIBER	ARAM.FIBER	ARAM.FIBER
19	GASKET	ALUMINIUM	ALUMINIUM	AISI 304	AISI 304	AISI 304	ALUMINIUM
20	GASKET	ARAM.FIBER	ARAM.FIBER	ARAM.FIBER	ARAM.FIBER	ARAM.FIBER	ARAM.FIBER
21	GASKET	ARAM.FIBER	ARAM.FIBER	ARAM.FIBER	ARAM.FIBER	ARAM.FIBER	ARAM.FIBER
22	SCREW	AISI 304	AISI 304	AISI 304	AISI 304	AISI 304	AISI 304
23	SCREW	AISI 304	AISI 304	AISI 304	AISI 304	AISI 304	AISI 304
24	PIN	AISI 304	AISI 304	AISI 304	AISI 304	AISI 304	AISI 304
25	RING NUT	AISI 431	AISI 431	AISI 431	AISI 431	AISI 431	AISI 431
26	LIFTING LEVER	AISI 303	AISI 303	AISI 303	AISI 303	AISI 303	AISI 303
27	LOCK NUT LEVER	AISI 303	AISI 303	AISI 303	AISI 303	AISI 303	AISI 303
28	CAMSHAFT	17-4PH	17-4PH	17-4PH	17-4PH	17-4PH	17-4PH
29	PACKING RING	PTFE	PTFE	PTFE	PTFE	PTFE	PTFE
30	GUIDE	AISI 304	AISI 304	AISI 304	AISI 304	AISI 304	AISI 304
31	PIN	AISI 304	AISI 304	AISI 304	AISI 304	AISI 304	AISI 304
32	PIN	AISI 304	AISI 304	AISI 304	AISI 304	AISI 304	AISI 304
33	BELLOWS	AISI 316L	AISI 316L	AISI 316L	AISI 316L	AISI 316L	-
34	PROTECTION BELLOWS	AISI 316	AISI 316	AISI 316	AISI 316	AISI 316	-
37	HEATING JACKET	CARB.STEEL	CARB.STEEL	AISI 304	AISI 304	AISI 304	-
38	TAST GAG	AISI 304	AISI 304	AISI 304	AISI 304	AISI 304	AISI 304
39	SOFT SEAT DISC	AISI 316	AISI 316	AISI 316	AISI 316	AISI 316	AISI 316
40	SOFT SEAT SCREW	AISI 316	AISI 316	AISI 316	AISI 316	AISI 316	AISI 316
41	GASKET	FPM RUBBER	FPM RUBBER	FPM RUBBER	FPM RUBBER	FPM RUBBER	FPM RUBBER

- 1. Available with stellited nozzle - code H6
- 2. Available with stellited nozzle and disc - code K6
- 3. Available with stellited nozzle - code 4H

- 4. Available with stellited nozzle - code 6H
- 5. Available with stellited nozzle and disc - code 6K
- 6. Available with stellited nozzle - code 95