

SAFETY VALVES

20000 SERIES TYPE 230 240

USE AND MAINTENANCE MANUAL

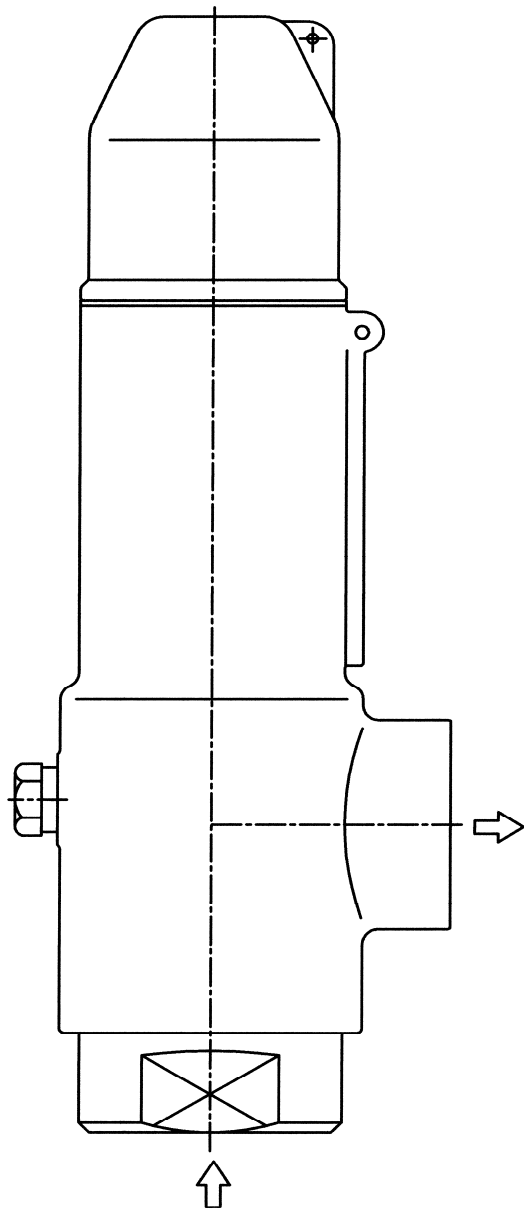

SAFETY VALVE FOR GASES, VAPOURS AND LIQUIDS

Characteristic

Homologation ASME / PED:

- overpressure 10%;
- spring range $\pm 5\%$ of set pressure ;
- gases and vapours discharge coefficient $K = 0,95$
PED & $K = 0,941$ ASME homologated ;
- liquids discharge coefficient $K = 0,6$.

Accessories

- Test gag;
- soft seat;
- lifting lever;

CHARACTERISTICS AND PRESSURE LIMITS

Type	Orifice				lift mm	Max. Set pressure bar	Max. Back pressure bar
	mm	Ø in	Area cm ²	Sq. in			
c	8	5/16"	0,502	0,078	1,6	140 with spring in AISI 316 600 with spring in alloy steel	28
d	9,5	3/8"	0,708	0,110	2,1		
e	12	121/256"	1,131	0,175	2,5	50 with spring Aisi 316 / alloy steel	10

20000 SERIES SAFETY VALVES

Safety valves **20000 Series**, designed and manufactured by **Technical s.r.l.** in accordance with international standard, are full nozzle and total lift type. They possess a high discharge coefficient ($k=0.95$) certified by **I.S.P.E.S.L.** and ($k=0.941$) certified by ASME/National Board on the basis of experimental tests performed by authorized laboratories; are suitable for gaseous and liquid fluids.

The valve body is integral with the bonnet and a ring nut contains the spring. The bonnet contains either a spiral spring or a Belleville spring, depending on the use and type of fluid.

The seat is plane and "metal on metal" type; it is possible to supply valves with a soft sealing ring (NBR or FPM rubber). Upon request, the valve is also available with accessories such as the packed lifting lever and test gag.

1. INSTALLING

Before installing the valve on the plant make sure that:

- the line fluid is indicated on the construction declaration or is compatible with the construction materials;
- the inlet piping in the valve are clean, impurities less, slag less etc. and eventually remove them;
- the inlet and discharge pipings are dimensioned in such a way that they generate the minimum possible loss of pressure.

In case the valve that is going to be installed is a **threaded type** use for tightening the key of the nozzle (1); if the valve is a **flanged type** tighten the bolts in a uniform way.

Once the valve has been installed on the plant make sure that:

- the discharge is not positioned in such a way to result dangerous for people or for instruments;
- the discharge is properly conveyed .

1.1 SETTING UP

Before shipment all the safety valves are hydrostatically tested and set at the setting pressure required by the Client. Therefore regulation in loco should not be necessary.

The maximum setting error is less than 3% for pressure up to 21 bar, with a minimum of 0,2 bar; it is less than 0,7 bar up to 70 bar; it is less than 1% for pressure over 70 bar.

In case it should be necessary to modify the set pressure or the re-closure pressure of the valve (blowdown) , it should be necessary proceed as follows:

1.1.1 setting regulation (referring to drawing)

In order to carry out setting regulation of the valve it is necessary:

- remove the cap (12) and loosen the lock nut (16);
- turn the adjusting screw (15) clockwise in case the set pressure should be increased;
- turn the adjusting screw (15) counter clockwise in case the pressure should be decreased.

The adjustment range of the spring setting is $\pm 5\%$ of the set pressure indicated on the label of the valve.

Once the valve setting is regulated tighten the lock nut (16) and re-screw the bonnet cap (12).

1.1.2 Type 230 blowdown ring regulation (table 1)

For the **230 Valve Type** with blowdown ring, if it would be necessary to change regulation, carry out the following operations:

- loosen the blowdown screw (8);
- lift the blowdown ring (5) turning it counter-clockwise until touch the nozzle (1);
- withdraw the blowdown ring (5), turning it clockwise, as indicated in **table 1**;
- tighten the blowdown screw (8) being assured that it does not block the blowdown ring (5) but that it stops the blowdown ring to turn only.

In case of more precise regulation of the ring (blowdown) is required, it is necessary carry out the regulation with the valve installed on the plant and at full flow, taking into consideration that:

- reducing the number of withdrawing notches it is favoured the opening and it is delayed the re-closure;
- increasing the number of withdrawing notches it is delayed the full opening and it is favoured the re-closure.

Table 1

BLOWDOWN RING ADJUSTING - ORIFICE CE - d - e								
Set pressure bar	0.5 ÷ 7	8 ÷ 15	16 ÷ 30	31 ÷ 60	61 ÷ 100	101 ÷ 150	150 ÷ 220	221 ÷ 330
n° of notches	1 ÷ 2	3	4 ÷ 5	6 ÷ 9	9 ÷ 12	12 ÷ 15	15 ÷ 18	18 ÷ 21

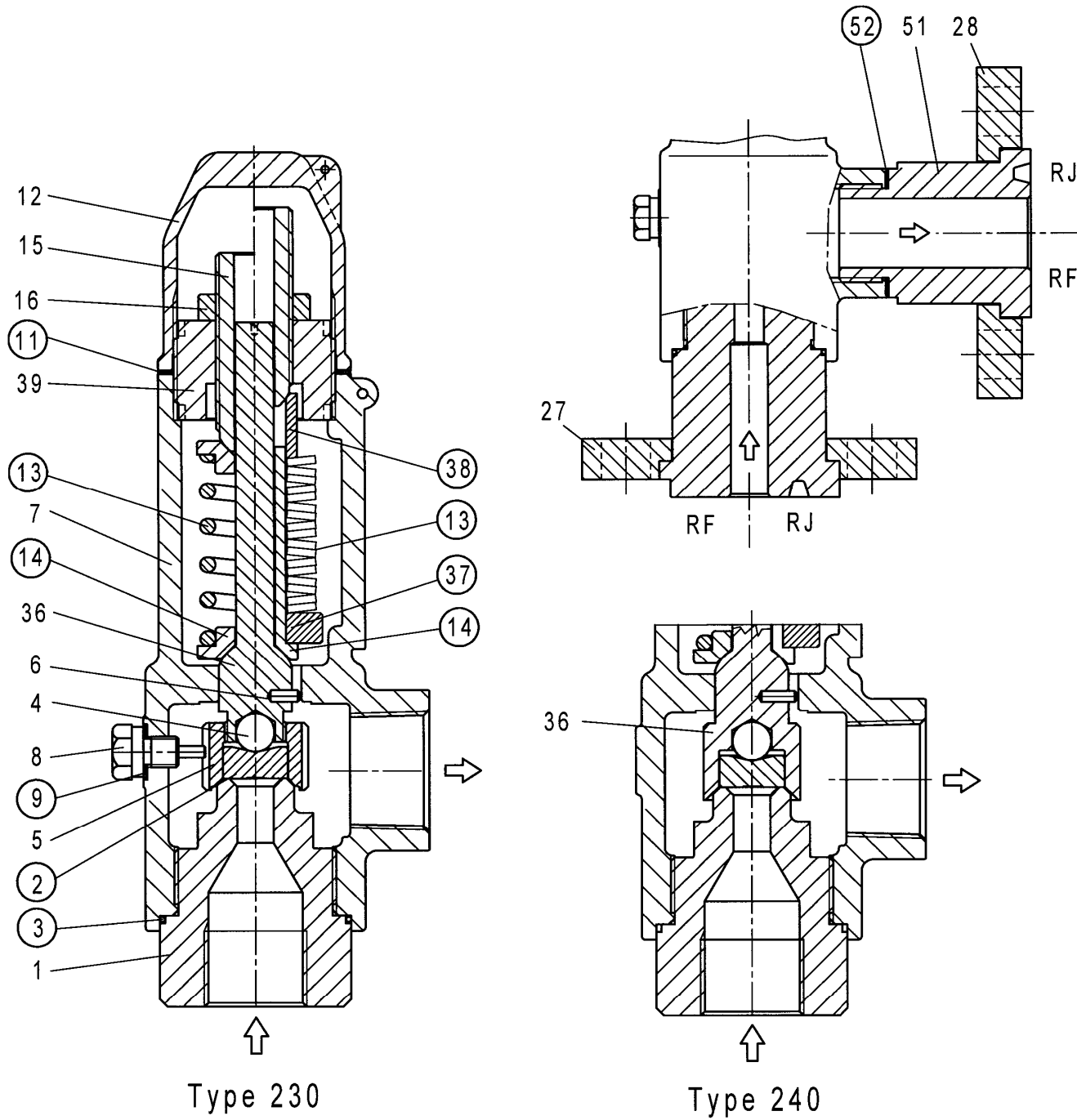

○ Recommended spare parts

2. DISASSEMBLING

2.1 VALVE WITHOUT ACCESSORIES

In order to execute disassembling carry out progressively the following operations:

CAUTION : before disassembling the valve make sure that the plant on which it is mounted is not “under pressure” and that no pressure inside the valve itself has remained.

- remove the valve from the plant;
- remove the bonnet (12) and loosen the lock nut (16)
- loosen the adjusting screw (15);

CAUTION : before disassembling the valve body make sure that the spring (13) is totally released using the adjusting screw (15).

- remove the ring nut (39), the spring (13) and the guide spring;
- remove the blowdown screw (8) [for 230 Type];
- loosen the nozzle (1) and remove all the internal parts.

2.2 VALVE WITH LEVER

In order to execute the disassembling of the valve with lever carry out progressively the following operations:

CAUTION : before disassembling the valve make sure that the plant on which it is mounted is not “under pressure” and that no pressure inside the valve itself has remained.

- remove the snap ring (48) and the lever (50);
- remove the lever guide (41) with the internal parts;
- remove the snap ring (49) the camshaft (40) from the lever guide (41);
- remove the lever cap (45);

Before removing the lock nut (44) and the lever nut (47) it is suggested to point out the distance between the ring nut (39) and the lever nut (47) in order to facilitate the next lever-group assembling.

- remove the lock nut (44) the lever nut (47) and loosen the lock nut (16) ;
- loosen the adjusting screw (15);

CAUTION : before disassembling the valve body make sure that the spring (13) is totally released using the adjusting screw (15).

- remove the ring nut (39) the spring (13) and the spring guides;
- remove the blowdown screw (8) [for 230 Type];
- loosen the nozzle (1) and remove all the internal parts.

3. ASSEMBLING

3.1 VALVE WITHOUT ACCESSORIES

For assembling carry out the same operations of point 2.1) but in reverse order. Before pushing the spring (13), for 210 Valve type make sure that the blowdown ring (5) is free and does not touch the nozzle (1).

3.2 VALVE WITH LEVER

For assembling carry out the same operations of point 2.2) but in reverse order. Before pushing the spring (13), for 230 Valve type make sure that the blowdown ring (5) is free and does not touch the nozzle (1).

Once assembled the valve and tightened the lock nut (16) it is necessary to put the lever nut (47) and the lock nut (44) at the same measure taken during the disassembling and tightening one against the other.

Screw the lever cap (45) and assemble in the following order camshaft (40) and the snap rings (49) in the lever guide (41) before screwing the same lever guide (41) on the lever cap (45); before tightening the lever guide (41) make sure that camshaft is in $0,2 \div 0,3$ mm from the lever nut (47), then tighten the lever guide (41) and put the lever (50) with the snap rings (48).

After assembling make sure that the lever can turn for 1/8 of turn easily with no efforts and without interfere with the lever nut (47), if it should not be so proceed with a new regulation of lock nut (44) and lever nut (47) or with a camshaft check.

4. MAINTENANCE

The safety valves requires an ordinary but careful maintenance (**SEE MAINTENANCE PLAN**) and in case it should be necessary , follow the operation stated in point **2**) for disassembling and in point **3**) for assembling.

In case of seat damaging it is necessary to carry out a new lapping: this operation has to be executed by skilled workers.

In case of inconveniences should occur to the valve, verify if in **DAMAGE TABLE** are contained some useful instructions for solving the problem.

If the damage is different from what stated in the table, contact our Service Department.

WARNING

- The safety valves should not be subjected to bumps or such stresses that could compromise the working.
- High loads on the spring can damage the valve.
- The safety valves must be used only exclusively for the use stated in the construction declaration.
- The safety valve must be revised within two years from installation for dangerous fluid (Group 1) and within three years for other fluids (Group 2) independently from the number of interventions executed by the valve.

ACCESSORIES

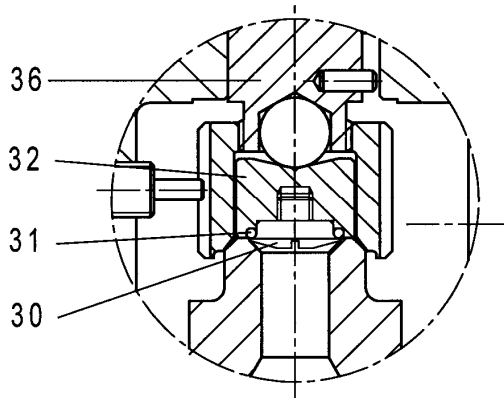

Soft Seat

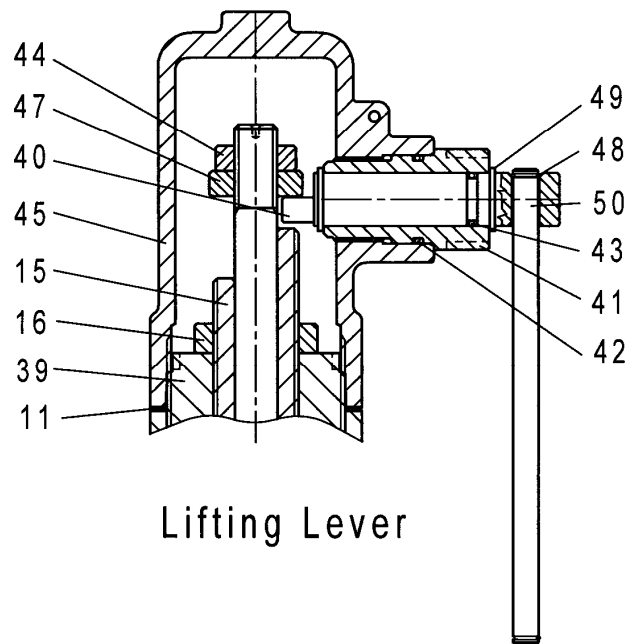

Lifting Lever

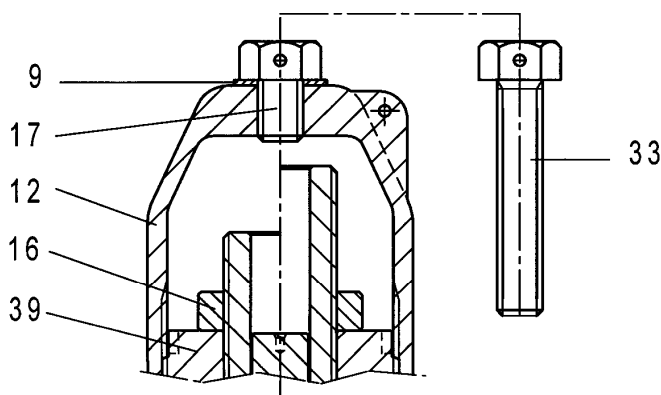

Test Gag

ORDINARY MAINTENANCE PLAN

Check of seat and disc tightness on the plant	Every valve opening or every 6-month working.
Check of outwards valve tightness in case of back pressure on the plant.	Every 30 days.
Check of the painting condition on the plant.	Every 6 months.
Ordinary maintenance of the valve installed on the plant, including the tightness check and the surface check of the movable components.	Every 12-month working.
General maintenance of the valve removed from the plant including the disassembling, the seat and the disc check, the incidental seat and disc lapping, gaskets substitution, painting restoration and test on the test bench.	Every opening with seats damaging or every 24-month working (Group 1) every 36-month working (Group 2)

DAMAGE TABLE

INCONVENIENT	POSSIBLE DAMAGE	ACTION TO BE CARRIED OUT
Fluid leakage in-line	Seat wear and tear	Nozzle substitution or revision
	Disc wear and tear	Disc substitution or revision
	Seat and disc damaging	Nozzle and disc revision
	Impurities presence between seat and disc	Nozzle and disc cleaning and revision
	Valve-use with fluid different from the one stated in the purchase order	Nozzle and disc revision
External back pressure fluid leakage.	Valve gaskets damaging	Gaskets substitution
	Valve body-bonnet damaging	Valve revision or substitution
	Cap or blowdown screw loosen	Check and setting-up of the cap and of the blowdown screw.
Opening at pressure value different from setting valve	Back pressure variable	Check of dimensioning and of the discharge piping working conditions and possible valve substitution with another type.
	Spring release	Spring substitution and check compatibility of the material with the fluid.
	Setting screw withdraw	Resetting the valve and tighten very well the lock nut
Valve intervention with quick opening and re-closures repeated in the time	Strong pressure loss in the inlet piping	Check the inlet piping length
	Not correct setting-up of the blowdown ring	Withdraw the blowdown ring until obtain a proper working, basing the first regulation one table 1; for liquid fluids withdraw the blowdown ring completely.
	Pulsating flow rate to be discharged	Check plant regulation.
	Over dimensioned valve	Substitute the valve with one correctly dimensioned.

MATERIAL TABLE SAFETY VALVE 20000 SERIES

TEMPERATURE LIMITE °C		- 20° +150°	- 29° + 350°			- 196° + 350°	- 196° + 100°
ITEM	PARTS	12	16 (1)	1L	H6	60 (2) (3) (4)	9X (5)
1	NOZZLE	AISI 431	AISI 316L	AISI 316L	AISI 316L STEEL	AISI 316L	AISI 316L
2	DISC	17-4PH	17-4PH	AISI 316L	17-4PH	17-4PH	AISI 316L
3	GASKET	FPM RUBBER	FPM RUBBER	FPM RUBBER	FPM RUBBER	FPM RUBBER	RUBBER
4	BALL	AISI 420	AISI 420	AISI 420	AISI 420	AISI 316	AISI 316
5	BLOWDOWN RING	AISI 303	AISI 303	AISI 303	AISI 303	AISI 316L	AISI 303
6	PIN	AISI 304	AISI 304	AISI 304	AISI 304	AISI 304	AISI 304
7	BODY	A 216WCB	A 216WCB	A 216WCB	A 216WCB	A351CF3M	BRONZE
8	BLOWDOWN SCREW	AISI 303	AISI 303	AISI 303	AISI 303	AISI 303	AISI 303
9	GASKET	ALUMINIUM	ALUMINIUM	ALUMINIUM	ALUMINIUM	AISI 316	ALUMINIUM
11	GASKET	ARAM. FIBER	ARAM. FIBER	ARAM. FIBER	ARAM. FIBER	ARAM. FIBER	ARAM. FIBER
12	CAP	A 216WCB	A 216WCB	A 216WCB	A 216WCB	A351CF3M	BRASS
13	SPRING	CARB. STEEL. / AISI 316L / INCONEL					
14	SPRING GUIDE	CARB. STEEL. / AISI 303 / AISI 316L / AISI 431					
15	ADJUSTING SCREW	AISI 431	AISI 431	AISI 431	AISI 431	AISI 431	AISI 431
16	LOCK NUT	CARB. STEEL	CARB. STEEL	CARB. STEEL	CARB. STEEL	AISI 303	AISI 303
17	SCREW	AISI 304	AISI 304	AISI 304	AISI 304	AISI 304	AISI 304
27	INLET FLANGE	CARB. STEEL	CARB. STEEL	CARB. STEEL	CARB. STEEL	AISI 316L	AISI 316L
28	OUTLET FLANGE	CARB. STEEL	CARB. STEEL	CARB. STEEL	CARB. STEEL	AISI 316L	AISI 316L
30	SOFT SEAT SCREW	AISI 316L	AISI 316L	AISI 316L	AISI 316L	AISI 316L	AISI 316L
31	GASKET	FPM RUBBER	FPM RUBBER	FPM RUBBER	FPM RUBBER	FPM RUBBER	RUBBER
32	SOFT SEAT DISC	AISI 316L	AISI 316L	AISI 316L	AISI 316L	AISI 316L	AISI 316L
33	TEST GAG	AISI 304	AISI 304	AISI 304	AISI 304	AISI 304	AISI 304
36	DISC HOLDER (TYPE 240)	AISI 431	AISI 431	AISI 431	AISI 431	17-4PH	BRONZE
36	DISC HOLDER (TYPE 230)	17-4PH	17-4PH	17-4PH	17-4PH	17-4PH	17-4PH
37	SPACER	AISI 316L	AISI 316L	AISI 316L	AISI 316L	AISI 316L	AISI 316L
38	UPPER SPRING GUIDE	AISI 431					
39	RING NUT	AISI 303	AISI 303	AISI 303	AISI 303	AISI 303	AISI 303
40	CAMSHAFT	17-4PH	17-4PH	17-4PH	17-4PH	17-4PH	17-4PH
41	LEVER GUIDE	AISI 316L	AISI 316L	AISI 316L	AISI 316L	AISI 316L	AISI 316L
42	GASKET	FPM RUBBER	FPM RUBBER	FPM RUBBER	FPM RUBBER	FPM RUBBER	FPM RUBBER
43	GASKET	FPM RUBBER	FPM RUBBER	FPM RUBBER	FPM RUBBER	FPM RUBBER	FPM RUBBER
44	LOCK NUT	AISI 304	AISI 304	AISI 304	AISI 304	AISI 304	AISI 304
45	LEVER CAP	CARB. STEEL	CARB. STEEL	CARB. STEEL	CARB. STEEL	AISI 316L	BRONZE
47	LEVER NUT	17-4PH	17-4PH	17-4PH	17-4PH	17-4PH	17-4PH
48	SNAP RING	AISI 316	AISI 316	AISI 316	AISI 316	AISI 316	AISI 316
49	SNAP RING	AISI 420	AISI 420	AISI 420	AISI 420	AISI 420	AISI 420
50	LEVER	AISI 316L	AISI 316L	AISI 316L	AISI 316L	AISI 316L	AISI 316L
51	NIPPLE	AISI 316L	AISI 316L	AISI 316L	AISI 316L	AISI 316L	AISI 316L
52	NIPPLE GASKET	ARAM. FIBER	ARAM. FIBER	ARAM. FIBER	ARAM. FIBER	ARAM. FIBER	ARAM. FIBER

1. Available with stellited nozzle and disc - code **K6**
2. Available with disc in AISI 316L - code **6L**
3. Available with stellited nozzle - code **6H**
4. Available with stellited nozzle and disc - code **6K**
5. Available with stellited nozzle and disc - code **9Z**

NOTE AGGIUNTIVE AL MANUALE DI USO E MANUTENZIONE – USE AND MAINTENANCE MANUAL'S NOTES SERIE 2000 – FORM 118 – 09/10

1 INSTALLAZIONE

E' necessario attenersi scrupolosamente alle indicazioni riportate nel Manuale per il serraggio della valvola sull'impianto e per lo smontaggio: utilizzare esclusivamente le fresature del boccaglio in modo da evitare forzature o allentamenti del corpo che potrebbero causare la fuoriuscita della spina dalla propria sede.

2 SMONTAGGIO

Lo smontaggio della valvola deve essere eseguito seguendo progressivamente le indicazioni riportate ai punti 2.1 e 2.2 del Manuale.

ATTENZIONE: E' tassativamente vietato iniziare lo smontaggio allentando il boccaglio -1- senza scaricare la molla ed aver rimosso le parti interne della valvola: questa operazione comprometterebbe l'integrità delle sedi ed il successivo montaggio potrebbe essere causa di rotture interne con conseguente malfunzionamento della valvola.

3 MONTAGGIO

Per il montaggio seguire le indicazioni del Manuale facendo attenzione ad assicurarsi che:

- inserendo il porta-otturatore -36- nel corpo -7- , la spina -6- sia posizionata correttamente nella cava del corpo;
- avvitando a mano il boccaglio -1- sul corpo -7- , l'operazione risulti fluida e senza resistenze fino a battuta meccanica;
- dopo il posizionamento a mano del boccaglio, ci sia libertà di movimento del porta-otturatore nel corpo (circa 3 – 4 mm);
- l'otturatore -2- sia inserito con la sede di tenuta lappata rivolta verso il boccaglio (vedere disegno).

4 MANUTENZIONE

Lo smontaggio, la manutenzione ed il montaggio delle valvole di sicurezza devono essere effettuati solamente da personale addestrato e qualificato per queste operazioni. La funzionalità delle valvole di sicurezza è vitale sia per la salvaguardia dell'impianto che per l'incolumità delle persone

1 INSTALLING

You must carefully follow the instructions in the manual for tightening the valve on the plant for disassembly: use only the wrench opening of the nozzle so as to avoid forcing or loosening of the body that may lead to the exit of the pin from its seat.

2 DISASSEMBLING

Disassembly of the valve must be carried out following progressively the instructions given in sections 2.1 and 2.2 of the Manual.

CAUTION: *It is strictly forbidden to start disassembling by loosening the nozzle -1- without unloading the spring and removing the internal parts of the valve: this would compromise the integrity of the seats and the following assembling could cause internal damage resulting in failure of the valve.*

3 ASSEMBLING

For assembling follow the instructions of the Manual, taking care to ensure that:

- *inserting the disc-holder -36- into the body -7- , the pin -6- is correctly positioned in the body slot;*
- *screwing by hand the nozzle -1- into the body -7-, the operation will be flowing with no resistance up to mechanical stop;*
- *after positioning by hand the nozzle, there is freedom of movement of the disc-holder in the body (about 3 - 4 mm);*
- *the disc -2- is inserted with the lapped seat facing to the nozzle (see drawing).*

4 MAINTENANCE

Disassembly, maintenance and installation of safety valves must be performed only by trained and qualified personnel for these operations. The functionality of the safety valves is vital both for the protection of the plant and for the safety of people.

