

SAFETY VALVES

SV 5001-H SERIES

USE AND MAINTENANCE MANUAL

SAFETY VALVES FOR GAS AND LIQUID SERVICE

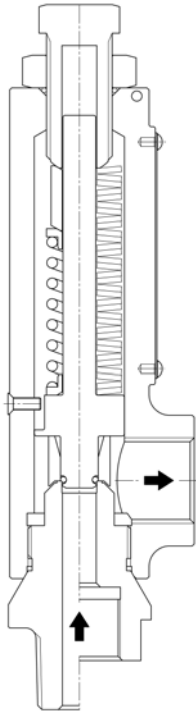

- complying with Directive 97/23/CE - PED;
- overpressure for gas and vapour 10%;
- overpressure for liquid 10%;
- gas and vapour discharge coefficient **K=0.7**;
- liquid discharge coefficient **K=0.6**;
- spring range $\pm 5\%$ of the set pressure;
- GAS or NPT threaded connections, female x female / male x female;
- Max set pressure 330 bar;
- body execution in A351CF3M;
- soft seat in rubber FPM, NBR, EPDM;
- sealing.

FIG.3

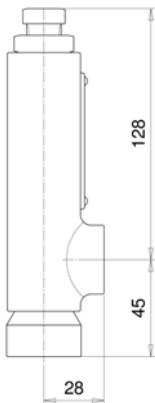
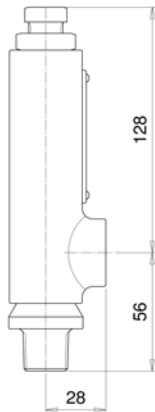

FIG.4



Model	Figure	Connections		Orifice	Valve seat
		inlet	outlet		
501-620-xx	3	1/2" NPT female	1/2" NPT female	Ø 8 0,502 cm ²	Soft
501-640-xx	4	1/2" NPT male	1/2" NPT female		
501-610-xx	3	1/2" Gas female	1/2" Gas female		
501-630-xx	4	1/2" Gas male	1/2" Gas female		
501-701-xx	3	1/2" NPT female	1/2" NPT female	Ø 8 0,502 cm ²	Metal
501-711-xx	4	1/2" NPT male	1/2" NPT female		
501-721-xx	3	1/2" Gas female	1/2" Gas female		
501-731-xx	4	1/2" Gas male	1/2" Gas female		

SV 5001-H SERIES SAFETY VALVE

The safety valve **SV 5001-H Series** are particularly indicated to protect tanks fed, low delivery pumps, pneumatic and hydraulic lines or to protect from thermal expansion. They can be used with either with liquid or with gaseous fluids at ambient temperature.

1. INSTALLING

Before installing the valve on the plant make sure that:

- the line fluid is indicated on the construction declaration or is compatible with what stated in it;
- the inlet piping the valve are impurities less, slag etc. and eventually remove them.
- the inlet and discharge piping are dimensioned in such a way that they generate the minimum possible loss of pressure.

Once the valve has been installed on the plant make sure that:

- the discharge is not positioned in such a way to result dangerous for people or for instruments;
- the discharge is properly conveyed .

1.1 SETTING UP

Before shipment all the safety valves are hydrostatically tested and set at the setting pressure required by the Client. Therefore regulation in loco should not be necessary.

The maximum setting error is less than 3% for pressure up to 21 bar, with a minimum of 0,2 bar; it is less than 0,7 bar up to 70 bar; it is less than 1% for pressure over 70 bar.

In case it should be necessary to modify the set pressure of the valve proceed as follows:

1.1.1 setting regulation (referring to drawing)

In order to carry out setting regulation of the valve it is necessary:

- loosen the lock nut (11);
- turn the adjusting screw (6) clockwise in case the set pressure should be increased;
- turn the adjusting screw (6) counter clockwise in case the pressure should be decreased.

The adjustment range of the spring setting is $\pm 5\%$ of the set pressure indicated on the label of the valve.

Once the valve setting is regulated tighten the lock nut (11).

2. DISASSEMBLING

In order to execute disassembling carry out progressively the following operations:

CAUTION : before disassembling the valve make sure that the plant on which it is mounted is not “under pressure” and that no pressure inside the valve itself has remained.

- remove the valve from the plant;
- loosen the lock nut (11) and the adjusting screw (6);

CAUTION : before disassembling the nozzle of the valve body make sure that the spring (10) is totally released using the adjusting screw (6).

- Overturn the valve;
- remove the nozzle (1) from the body (7);
- remove all internal parts.

3. ASSEMBLING

For assembling carry out the same operations of point 2) but in reverse order. Be sure to tighten the nozzle (1) on the body (7)

4. MAINTENANCE (enclosure A)

The safety valves requires an ordinary but careful maintenance (**SEE MAINTENANCE PLANT**) and in case it should be necessary, follow the operation stated in point 2) for disassembling and in point 3) for assembling.

In case of seat damaging it is necessary to carry out a new lapping: this operation has to be executed by skilled workers.

In case inconvenience should occur to the valve, verify if in the **DAMAGES TABLE** are contained some useful instructions for solving the problem.

In case the inconvenience is of different nature from what stated in the table, contact our Service Dept.

WARNING

- **The safety valves should not be subjected to bumps or such stresses that could compromise the working.**
- **High loads on the spring can damage the valve.**
- **The safety valves must be used only exclusively for the use stated in the construction declaration.**
- **The safety valve must be revised within two-three years from installation independently on the number of interventions executed by the valve.**

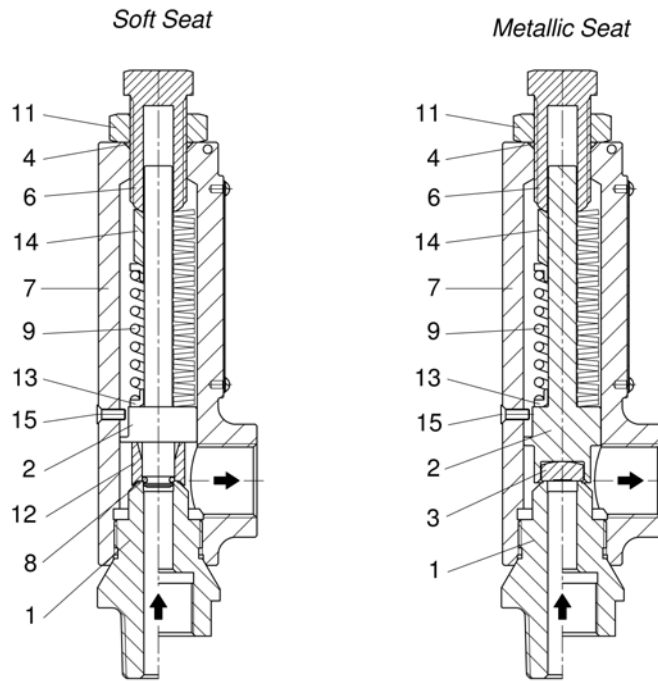

FIG.1

FIG.2

Temperature limits		-5 ÷ +150°C	-15 ÷ +100°C	-5 ÷ +150°C	-15 ÷ +100°C	-15°C ÷ +250°C		
Setting pressure		2 ÷ 27 bar		27,1 ÷ 150 bar		2 ÷ 150 bar		2 ÷ 330 bar
Material Class		66	67	60	65	60	65	64
Item	Part	soft seat				metallic seat		
1*	Nozzle	AISI 316L	AISI 316L	AISI 316L	AISI 316L	AISI 316L	AISI 316L	AISI 630
2	Disc holder	AISI 316L	AISI 316L	AISI 316L	AISI 316L	AISI 316L	AISI 316L	AISI 316L
3*	Disc	\	\	\	\	AISI 316L	AISI 316L	AISI 630
4*	Gasket	FPM RUBBER 75 SHORE	NBR RUBBER 75 SHORE	FPM RUBBER 75 SHORE	NBR RUBBER 75 SHORE	FPM RUBBER 75 SHORE	NBR RUBBER 75 SHORE	FPM RUBBER 75 SHORE
6	Adjusting screw	AISI 316L	AISI 316L	AISI 316L	AISI 316L	AISI 316L	AISI 316L	AISI 316L
7	Body	A351CF3M	A351CF3M	A351CF3M	A351CF3M	A351CF3M	A351CF3M	A351CF3M
8*	Gasket	FPM RUBBER 75 SHORE	NBR RUBBER 75 SHORE	FPM RUBBER 90 SHORE	NBR RUBBER 90 SHORE	\	\	\
9	Spring	AISI 316		AISI 316 up to 125 bar Alloy steel up to 130 bar		AISI 316 up to 125 bar Alloy steel up to 130 bar		
11	Lock nut	AISI 316L	AISI 316L	AISI 316L	AISI 316L	AISI 316L	AISI 316L	AISI 316L
12	Bell	AISI 316L	AISI 316L	AISI 316L	AISI 316L	\	\	\
13	Spring guide	AISI 316L	AISI 316L	\	\	AISI 316L	AISI 316L	AISI 316L
14	Spacer	AISI 431	AISI 431	AISI 431	AISI 431	\	\	\
15	Screw	AISI 316	AISI 316	AISI 316	AISI 316	AISI 316	AISI 316	AISI 316
*Recommended spare parts		Fig. 1				Fig. 2		

We are able to supply also other connections on request

ORDINARY MAINTENANCE PLAN	
Check of the seat and disc on the plant	Every valve opening or every 6-month working.
Check of the seal outwards in case of back pressure on the plant.	Every 30 days.
Ordinary maintenance of the valve assembled on the plant, including the seal check and surface check of the movable components.	Every 12-month working.
General maintenance of the valve removed from the plant including the disassembling, the seat and the disc check, the possible seat and disc lapping, gaskets substitution, painting restoration and inspection on the test bench.	Every opening with seats damaging or every 24 month working.(Group I) every 36 month working (Group II)

DAMAGES TABLE		
INCONVENIENT	POSSIBLE DAMAGE	ACTION TO BE CARRIED OUT
Fluid leakage in-line	Seat wear and tear	Nozzle substitution or revision
	Disc wear and tear	Disc substitution or revision
	Seat and disc damaging	Nozzle and disc revision
	Impurities presence between seat and disc	Nozzle and disc cleaning and revision
	Valve-use with fluid different from the one stated in the purchase order	Nozzle and disc revision
External back pressure fluid leakage.	Valve gaskets damaging	Gaskets substitution
	Valve body-bonnet damaging	Valve revision or substitution
	Cap or blowdown screw loosen	Check and setting-up of the cap and of the blowdown screw.
Opening at pressure value different from setting valve	Back pressure changeable	Check of dimensioning and of the discharge piping working conditions and possible valve substitution with another type.
	Spring release	Spring substitution and check compatibility of the material with the fluid.
	Setting screw withdraw	Resetting the valve and tighten very well the lock nut
Valve intervention with quick opening and re-closures repeated in the time	Strong loss load in the inlet piping	Check the inlet piping length
	Not correct setting-up of the blowdown ring	Withdraw the blowdown ring until obtain a proper working, basing the first regulation one table 1; for liquid fluids withdraw the blowdown ring completely.
	Pulsating flow rate to be discharged	Check plant regulation.
	Overdimensioned valve	Substitute the valve with one correctly dimensioned.